

FB-3300

Polyphonic Synthesizer

Version 1.0

© 2017-2019 by Björn Arlt @ Full Bucket Music
<http://www.fullbucket.de/music>



VST is a trademark of Steinberg Media Technologies GmbH
Windows is a registered trademark of Microsoft Corporation
The Audio Units logo is a trademark of Apple Computer, Inc.

Table of Contents

- Introduction.....4
- History.....4
- Digital Transformation.....4
- Acknowledgments.....5
- Architecture.....6
- Polyphonic Section.....7
 - Signal Generators (SG).....7
 - Lowpass Filters (LP).....7
 - Envelope Modifiers (EM).....8
- Monophonic/Paraphonic Section.....9
 - Resonators.....9
 - Amplitude Modulation.....9
 - Signal Modifiers.....9
 - Modulation Generators.....10
- Mixer Section.....10
- Global Modulators.....11
 - Sample & Hold.....11
 - General Envelope Generator (GEG).....11
 - Voltage Processors.....11
 - LAG Processors and Attenuators.....12
 - External Trigger and Modulation Sources 12
- Tweaks.....13
 - Context Menus.....13
- Options Menu.....14
- The *fb3300.ini* Configuration File.....15
 - MIDI Control Change Messages.....15
 - MIDI Learn.....15
- Modulation and Trigger Sources.....16
- Block Parameters.....18
 - Temperament (Micro-Tuning).....18
 - Signal Generators.....18
 - Lowpass Filter.....19
 - Envelope Modifier.....19
 - Resonators.....20
 - Signal Modifiers and VCA.....20
 - Modulation Generators 1/2.....21
 - Tweaks.....21
- Global Parameters.....22
 - Global VCA and Controls.....22
 - Sample & Hold.....22
 - General Envelope Generator.....22
 - Voltage Processors 1 and 2.....23
 - External Modulation and Trigger Sources 23
 - Tweaks.....23
- Frequently Asked Questions.....24

Introduction

The *FB-3300* is a software synthesizer plug-in for Microsoft Windows (VST) and Apple macOS (VST/AU) simulating the classic KORG PS-3300 polyphonic analog synthesizer from 1977. It is written in native C++ code for high performance even on “lighter” systems. The main features are:

- Close emulation of behavior and all controls of the original hardware
- Three independent polyphonic synthesizer blocks
- Band-limited oscillators, classic two-pole lowpass filters
- Resonators sections plus two Modulation Generators per bank
- Additional Sample & Hold and paraphonic Envelope Generator
- Semi-modular
- Micro-tuning option
- Additional tweaks
- Plug-in supports Windows and macOS (32 bit and 64 bit)

History

In 1977, KORG released two new synthesizer, the *PS-3100* and the *PS-3300*, where “PS” is short for *Polyphonic Synthesizer*. By that time not many polyphonic synthesizers were around, and being even *fully* polyphonic the PS brothers (in close approximation the PS-3300 consists of three PS-3100) were propelled into the noble company of a Polymoog.

While the PS-3100 is a rather modest instrument, the PS-3300 features no less than 3 independent synthesizer blocks (comparable to almost a full PS-3100): Each block has 48 voices with 48 filters and 48 envelopes but only 12 oscillators generating the top octave frequencies for the twelve keys C to B. The remaining 36 signals are derived by frequency division... but the PS-3300 is not just a sophisticated organ.

The PS-3300 is *huge*.

Compared to the PS-3100, the PS-3300 has lost its “MS-20-like” patch bay. Instead, the plugs are positioned below the relevant modules which makes the PS-3300 look like a classic modular system (although it is “just” semi-modular). The three synthesizer blocks are accompanied by a global mixer section plus some modules already known from the PS-3100 (Sample & Hold, General Envelope Generator, and Voice Processors). However, the PS-3100 outnumbers the PS-3300 when it comes to units produced: Rumor says that only a few hundred 3300ers have ever been built.

1978, one year later, came the PS-3200, KORG's first *programmable* polyphonic synthesizer.. but that's another story.

Digital Transformation

In 2017 and only forty years after its release, I took a closer look at the PS-3100 and to my surprise found many features that are pretty unique to this amazing machine. Having finishing my own simulation, the *FB-3100*, I consequently started the next project: The *FB-3300*.

Aim of the project was to provide a close simulation of the original hardware and not some highly evolved, hyper-extended, next generation *SuperPS-3300++ deluxe* (be assured that the PS-3300 does not need that!). As usual, this included some decisions that some folks maybe do not like:

- The FB-3300 does not react to Velocity.
- The monophonic/paraphonic modulation options of the PS-3300 remain monophonic/paraphonic in the FB-3300.
- The UI is too small. This is *always* true. ☺
- At the same time the UI is *too big*; it may not fit on smaller screens. But I saw no acceptable way of shrinking its size without killing usability and elegance.
- The plugs of the FB-3300 do not use virtual patch cords but “patch menus”.

I am pretty sure that especially the last bullet will cause a storm of protest. But here is my point: Since the panel is already pretty crowded (and of course too small and too big, see above) I strongly believe that lingering “patch cords” will not help to visualize the current patch connections either. Another advantage is that *patch junctions* (ports that provide multiple “copies” of the original source) are not needed.

On the other hand I added some tweaks not to be found on the PS-3300:

- The three blocks can be individually placed in the stereo panorama.
- The funny *Hold* mode behavior can be overridden with the somehow more intuitive “expected standard behavior” of a Hold function.
- The three-step *EM Release* switch can be overridden by a continuous Release control knob.
- Modulation Generators and Sample & Hold can be synchronized to the host.
- MIDI controllers can be used as sources for virtual voltages and triggers.
- The FB-3300 features a few more modulation sources than the PS-3300.
- Two LAG processors and three attenuators are added for convenience.

Acknowledgments

- Thanks a lot to **Martin Lueders** (PG8X...), **Taymur Streng**, and **Manfred Hasenfus**¹ for support, beta testing, and patch programming!
- A big **Thank you!** goes to all the people who share their information about the PS synthesizers via the Internet.
- Some of the micro-tuning templates are derived from the **Microtonal Synthesis** website at <http://www.microtonal-synthesis.com/>.
- Furthermore a **BIG THANKS** to **Tim Stinchcombe** and **Will Pirkle** for their in-depth analysis of the K35 filter chip.
- Last not least another THANK YOU! to the KVR Audio community and to the KORG engineers.

No, I am not affiliated with KORG in what relation ever except that I always find myself entangled with their instruments. ☺

1 The factory presets 54 to 62 are Manfred’s creation.

Architecture

The FB-3300 provides three synthesizer *blocks* that run in parallel to each other. Each block has 64 voices, and each voice features a band-limited *Signal Generator (SG)*, a 2-pole *Lowpass filter (LP)*, an *Envelope Modulator (EM)*, and two *Modulation Generators (MG 1+2)*. The mix of all voices is sent into a single (!) *Resonators* section consisting of three bandpass filters/resonators, followed by an *Amplitude Modulation* section and a *Voltage Controlled Amplifier (VCA)*.

Finally, the output of the three blocks is summed up in a final VCA. For modulation purposes the FB-3300 has a *Sample & Hold* unit, an additional *General Envelope Generator (GEG)*, and two *Voltage Processors (VP 1+2)*.

As you can see from the block diagram, there are many signal (solid) and modulation (dashed) paths between the various modules. The configuration is pretty flexible and can be reconfigured by using the plugs. You can see, too, that further processing of the polyphonic signals after the LP section is *monophonic* (better: *paraphonic*). For example the modulation of a VCA does affect the volume of *all* voices of a block and not that of an *individual* voice. In the same sense the GEG acts as a paraphonic envelope and not *per voice*. Even more, modulating the final VCA affects *all* voices of *all* blocks.

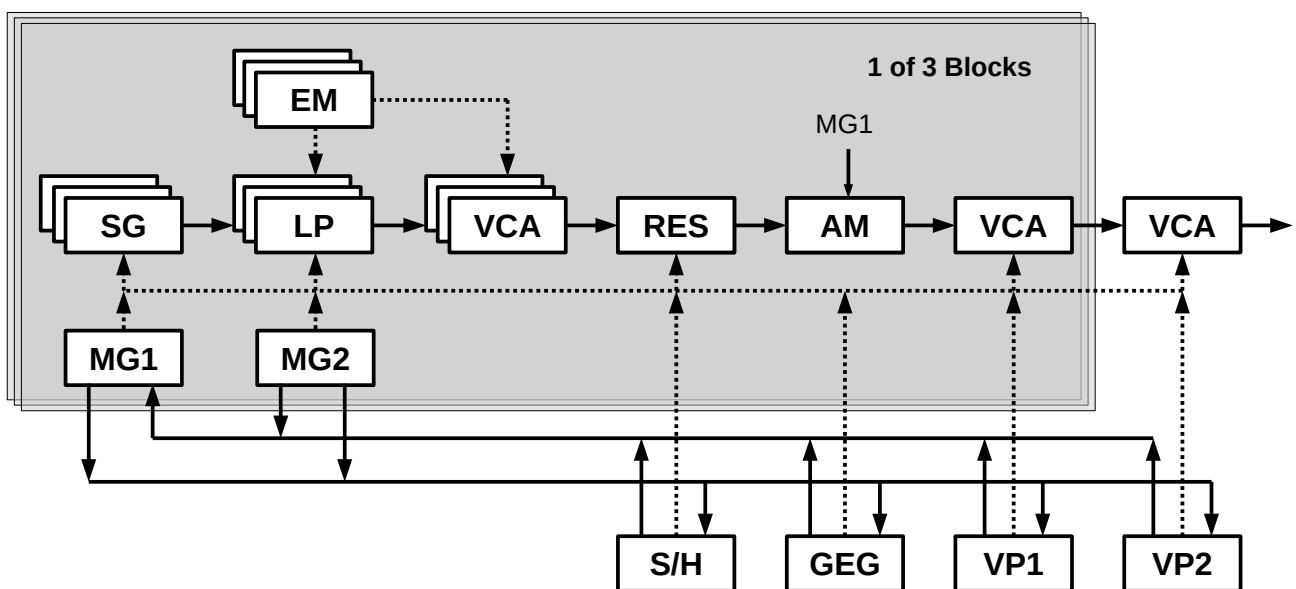

Polyphonic Section

The following applies to each of the three blocks A, B, and C.

Signal Generators (SG)

The Signal Generators offer six selectable waveforms (*Triangle, Sawtooth, Square, Rectangle, Pulse, and Pulse Width Modulation*), four octave ranges (16' to 2'), fine and coarse tuning and frequency modulation controls. Note that per key (C to B) only one *top-octave* oscillator exists – the lower octaves are generated by frequency division. Thus, the signals of the same key at different octaves are always *in phase*; you can verify this by analyzing the output of the FB-3300 with an oscilloscope.

Frequency modulation (FM) can be enabled by the orange switch at the right of the SG section; the other orange switch ("REV.") to the left flips the polarity of the modulation. While the first source for FM is always given by MG1, the second modulation source has to be selected via the plug *FRQ*. Pulse Width Modulation is by default performed by MG2 but can be set to any other source (plug *PWM*).



An interesting feature is the *micro-tuning* option. Each of the 12 keys can be tuned individually, allowing for other (not necessarily well-tempered) tunings like *Pythagorean* or *Wendy Carlos' Super Just* tuning etc. The small button at the bottom of the tuning knobs opens a menu with 14 predefined micro-tuning templates. Here it is also possible to load and/or save the tuning settings from/to a Scala (*.scl) file.

Lowpass Filters (LP)

The output of the Signal Generators is fed into a two-pole lowpass filter section with adjustable resonance (*Peak*). Yes, this is an emulation of the famous KORG K-35 filter but as in the PS-3300 it cannot be pushed to self-oscillation. Sorry.

Cutoff frequency modulation comes in various ways: First of all the cutoff can be controlled by the note played (*KBD Balance*) both in positive and negative direction (here *negative* means that the cutoff frequency will be *lower* for *higher* notes).

The next knob, *Expand*, controls the influence of the Envelope Modifier (see next section) on the cutoff frequency while the remaining options for frequency modulation resemble those of the Signal Generators: Activated

by the orange switch, the filter can be modulated by MG1 and a second source. The latter setting can be changed via the plug *FRQ* at the bottom.

Envelope Modifiers (EM)

The envelopes are of the standard *ADSR* type except that the release time cannot be controlled continuously but only in three steps: *Damp* (very short), *Half Damp* (pretty short) and *Release* (pretty long). FB-3300 owners will love the option to override the Release time by a variable amount (see section *Tweaks*).

Another funny feature is the *Hold* function: When switched on the envelope does not go into the Release phase once a key is unpressed; instead you have to press the same key *again* to release it.

Working with the Hold function can be tricky because it will only get activated if the Attack time setting is higher than 70% (i.e. the Attack knob is turned almost fully to the right). Furthermore, deactivating the Hold function requires the Attack time setting to be less than 30% (i.e. the Attack knob is turned almost fully to the left). If you are confused now: Go to the *Tweaks* section and learn how to override this weird behavior.

The attack time can be externally controlled by a modulation source plugged into *ATK* while a trigger signal from a source plugged into *REL* will put the EM into the release phase (i.e. stop the envelope). This can be handy when the EM is in Hold mode and you need to reset the voices without turning Hold mode off (for example use the manual TRG1 switch as source for *REL*).



Monophonic/Paraphonic Section

The following applies to each of the three blocks A, B, and C.

Resonators

As stated above the individual voice signals are mixed into a single monophonic signal and sent into the *Resonators* section. This is basically a parallel arrangement of three bandpass filters with high Q (i.e. resonators) and individually adjustable center frequencies. The "INTENSITY" control determines the mix between original and effect signal.

The resonator frequencies can be modulated by MG2 via the "MG2 MOD" switch and/or by an additional source that has to be selected via the plug *RES FRQ*.

The Resonators section has become pretty famous and is one of the key features giving the PS-3100/3300 brothers their "signature sound". Unfortunately, it was replaced in the PS-3200 by a static (!) 7-stage equalizer.



Amplitude Modulation

Following the Resonators, the signal runs through an *Amplitude Modulator* which multiplies it with the signal of MG1 (can be disabled by using the orange switch to the bottom of the Amplitude Modulation section). Here, the "AMP MOD" knob sets the intensity and character of the effect as follows:

- The range from 0% to 50% (i.e. from the very left to the center of the knob range) will result in a *Cross Modulation* effect. This means that the amplitude of the signal is modulated from $-\infty$ dB to a maximum of 0dB.
- The range from 50% to 100% (i.e. from the center to the very right of the knob range) will result in a *Ring Modulation* effect meaning that negative values of the MG1 signal will (apart from attenuation) cause the modulated signal to be *inverted*. This makes perfect sense if you think of Ring modulation as a *multiplication*.



The interesting thing is that MG1 is able to generate signals in the kilohertz range which allows for drastic sound effects. But even in the low range a Ring Modulation with a sawtooth wave can result in unusual gate effects.

Signal Modifiers

After Amplitude Modulation the signal is treated by a pretty unique feature: The *Keyboard Balance* which adjusts the volume of notes as played on the keyboard. With this control you can attenuate notes on the lower end or vice versa.

Finally, the *Pan* control places the output of the whole block in the stereo panorama.



Modulation Generators

Each block has two *Modulation Generators* (LFOs). The second one, *MG2*, only offers a triangle wave while the first one, *MG1*, is much more flexible and can produce a triangle, a falling or rising sawtooth, and a square wave as well as (pretty uncommon!) *Pink Noise* and *White Noise*. Except for the noise waves (which have a continuous frequency range) the frequency of *MG1* can be set up to about 1.6kHz – again a very uncommon but nice feature!



Both *MGs* can be synchronized to the host tempo. Furthermore, by patching appropriate sources, one can *modulate* the intensity (plug *MOD*) and frequency (plug *FRQ*) of *MG1*.

Mixer Section

The signals of all three blocks is summed up in the *Signal Mixer* section. Each signal can be adjusted in volume and modulated via *VCA* by a modulation source (plug *MOD*). Furthermore, each signal can be gated manually or by a different modulation source (plug *GATE*). Here, any “voltage” higher than 0 Volts sets the gate to “ON” (provided the associated switch is also set to “ON”) while voltages lower than 0 Volts sets it to “OFF”.

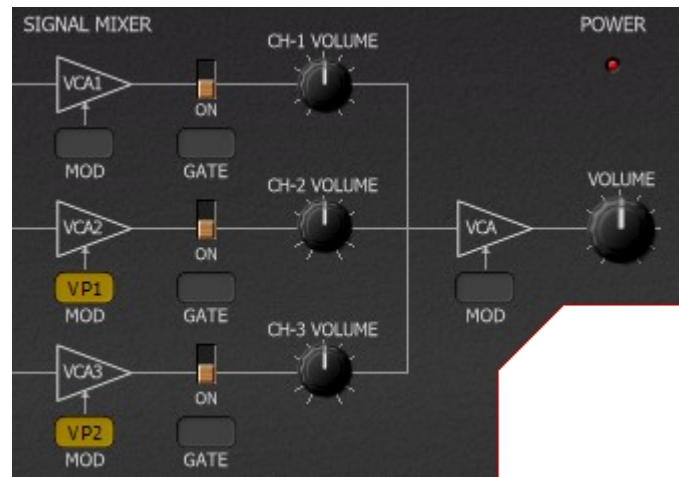

Finally, the total signal is sent again through a final *VCA*. Note that the final output is a stereo signal since the output of each block can be placed in the stereo panorama. On the *PS-3300*, you would need a separate stereo mixer for this.

Global Modulators

Sample & Hold

The *Sample & Hold (S/H)* unit samples whatever signal is sent into the input plug *IN*. The sample rate can be synchronized to the host tempo.

The "SYNC" switch (called "SYNCHRO" on the PS-3300) is bit funny. KORG's original documentation states that "*when the sampled frequency is near the clock frequency multiplied by an integer, the clock is synchronized*". Well, better check it out by yourself. Fact is that a regular/periodic input signal can produce some regular, repetitive output while noise will create random patterns. In any case the SYNC function is disabled when the S/H clock is synchronized to the host tempo.



General Envelope Generator (GEG)

The GEG is a simple *AR* envelope with an additional *Delay* parameter. It can be turned into an *AD*-like envelope by enabling the "AUTO" switch: In this case the GEG – once triggered – will ignore the Sustain phase and go immediately into the Release phase.



The GEG can be triggered by any trigger signal patched into one of the two plugs *TRG1* and *TRG2*. Of special interest is the "KBD TRIGGER" source: Here you can select how many keys (1 to 5) have to be pressed before this trigger source is triggered (in the "Off" position the keyboard by default does not trigger at all).

What's not on the PS-3300 is the status LED that shows the current on/off state of the GEG – I think this is a very convenient yet non-obstructive addition.



Voltage Processors

There are two *Voltage Processors*, *VP1* and *VP2*, on board the FB-3300. They are used to process the signal of a modulation source (e.g. a MG or the GEG) and to produce a modified signal. Here is how that works:

Typically, a signal source can vary from something like -5 to +5 (virtual) Volts. A Voltage Processor will change the range these input values will be mapped to, for example from -2.5 to +1.8 Volts. The input range even can inverted, for example from +3.4 to -4.2 Volts. The limits of the output ranges are set by the "LIMITER A" and "LIMITER B" knobs where "LIMITER B" defines the low end of the range (in the examples above -2.5 and +3.4 Volts) and "LIMITER A" the high end (in the examples above +1.8 and -4.2 Volts).

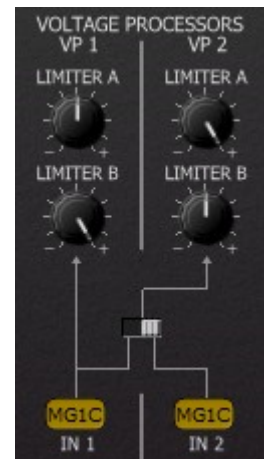

LAG Processors and Attenuators

The two LAG processors and three attenuators are not part of the original PS-3300 design. However, these little tools are very common in modular synthesizers and pretty helpful, so I decided to add them to the FB-3300.



A LAG processor smoothes an incoming signal according to the amount of its control value setting – a classic example is the *Portamento* effect where the keyboard control voltage “glides” between the values of two subsequently pressed keys instead of abruptly changing. Technically a LAG processor is a lowpass filter with a very low cutoff frequency.

Attenuators are even simpler: They multiply the incoming signal with a fixed value and can also be used to invert it.

External Trigger and Modulation Sources

Strictly speaking there are two types of sources and targets: *modulations* and *triggers*. For example the *ATK* target plug of the EM continuously modulates the Attack time while the *REL* target plug waits for a trigger signal to release the envelopes.

There are some additional modulation (“VC1” to “VC8”) and trigger sources (“Clk1” to “Clk4”, “Trg1”, “Trg2”) available. The “Clk” sources provide variable clock triggers synchronized to the host tempo, the “Trg” sources create trigger signals from assignable MIDI Control Change messages (the trigger occurs when the controller value passes from a value above 63 to a value below 63, emulating a “falling-edge ground trigger”), and the “VC” modulation sources create modulation signals from assignable MIDI Control Change messages. In the Patch Bay you can choose these sources like any other source.

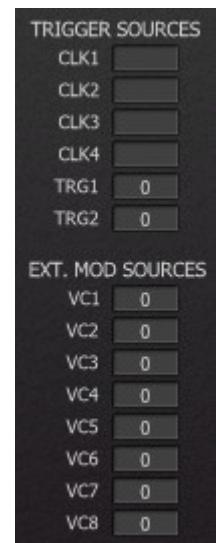

When hovering with the mouse over a modulation/trigger target, the properties of both the target and the assigned source (if any) will be displayed in the info block at the bottom right of the FB-3300’s panel.

Tweaks

In the section *Digital Transformation* above it has already been mentioned that the FB-3300 contains some additional features (*tweaks*) that the original PS-3300 hardware synthesizer does not have.

- Additional modulation sources "Key", "PB", "PB+", "MW", "MW+", "LAG1", "LAG2", "ATT1" to "ATT3", "VC1" to "VC8"
- Additional S/H input sources "Rnd"
- Additional trigger sources "Clk1" to "Clk4", "Trg1", "Trg2"
- Panorama control for each block signal output
- Override for PS-3300 EM Hold mode and Release time
- LAG processors and attenuators.

Not really a tweak (since the PS-3300 does feature a momentary switch) but nonetheless helpful is the "MANUAL TRG1" push button that – when clicked – raises a trigger impulse for the "Trg1" trigger source.



Context Menus

It can be pretty tedious to edit all the parameters of the FB-3300, thus there are several context menus to help you. For example, you can copy all the parameters of one block to another block by clicking the drop down menu at the top right of each block.

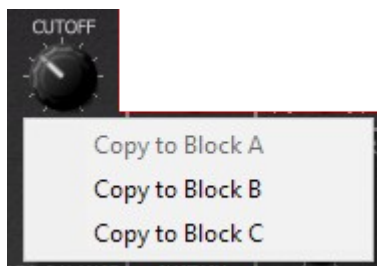
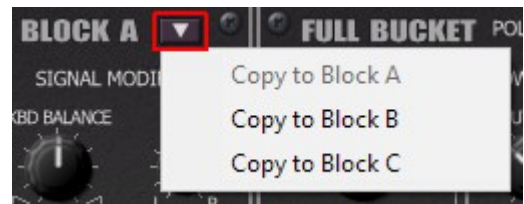

Or you can right-click on any block parameter and copy its value to the same parameter of another block. This works also for the Volume/Gate parameters in the mixer section and the tweak Release parameters.

Options Menu

When clicking on the *Menu* button, a context menu opens with the following options:

Copy Program	Copy current program to internal clipboard
Paste Program	Paste internal clipboard to current program
Load Program	Load a program file containing a patch to the FB-3300's current program
Save Program	Save the FB-3300's current program to a program file
Load Bank	Load a bank file containing 64 FB-3300 patches
Save Bank	Save the FB-3300's 64 patches to a bank file
Init Program	Initialize the current program
Reload Configuration	Reload the FB-3300's configuration file (see section <i>The fb3300.ini Configuration File</i>)
Save Configuration	Save the FB-3300's configuration file (see section <i>The fb3300.ini Configuration File</i>)
Select Startup Bank	Select the bank file that should always be loaded when the FB-3300 is started
Load Startup Bank	Load the Startup bank file; can also be used to check what the current Startup bank is
Unselect Startup Bank	Unselect the current Startup bank
Check Online for Update	When connected to the Internet, this function will check if a newer version of the FB-3300 is available at fullbucket.de
Visit fullbucket.de	Open fullbucket.de in your standard browser

The *fb3300.ini* Configuration File

The FB-3300 is able to read some settings from a configuration file (*fb3300.ini*) located in the same directory as the FB-3300 VST DLL (*fb3300.dll* or *fb330064.dll*) or Mac VST/AU (*FB3300.component* or *FB3300.vst*) itself. After you have edited this INI file in a text editor, you have to reload it using the *Reload Configuration* command from the *File* menu (see section *The fb3300.ini Configuration File*).

MIDI Control Change Messages

All parameters of the FB-3300 can be controlled by MIDI controllers, or more precise: Each MIDI controller (except *Modulation Wheel* and *Sustain Pedal*) can control one of FB-3300's parameters. The mapping is defined in the *fb3300.ini* for example like this:

```
[MIDI Control]
CC7  = 183 # Total Volume
CC70 = 23  # LP Cutoff Block A
CC71 = 24  # LP Peak Block A
...
```

The syntax is straight forward:

```
CC<controller number> = <parameter ID>
```

Given the above example, controller 7 directly controls the overall *Volume* parameter, controller 74 the *LP Cutoff* etc. As you can see, comments are introduced by the Pound sign (#); they are here just for description purposes and completely optional.

MIDI Learn

The easiest way to assign MIDI controllers to FB-3300 parameters is to use the MIDI Learn function. To activate *MIDI Learn*, click on the respective button and wiggle both the MIDI controller and the FB-3300's parameter that you want to link. If you want to unlearn the assignment, right-click the *MIDI Learn* button (the label now reads "UNLEARN") and activate it. Now wiggle the MIDI controller or the parameter that you want to unlearn.

Modulation and Trigger Sources

Modulation Sources			
Name	Voltage	Group	Description
off	0	-	off / default
+5V	+5	-	on
GE1-	0 to 5	Intern	GEG inverted output
GE2+	-5 to 0	Intern	GEG normal output
GE3+	0 to 5	Intern	GEG normal output
MG1A	-5 to 5	Intern	MG1 (block A) output
MG2A	-5 to 5	Intern	MG2 (block A) output
MG1B	-5 to 5	Intern	MG1 (block B) output
MG2B	-5 to 5	Intern	MG2 (block B) output
MG1C	-5 to 5	Intern	MG1 (block C) output
MG2C	-5 to 5	Intern	MG2 (block C) output
S/H²	-5 to 5	Intern	S/H output
VP1	-5 to 5	Intern	VP1 output
VP2	-5 to 5	Intern	VP2 output
Key	-5 to 5	Extern	last pressed key
PB	-5 to 5	Extern	Pitch Bend
PB+	0 to 5	Extern	Pitch Bend positive
MW	-5 to 5	Extern	Mod Wheel
MW+	0 to 5	Extern	Mod Wheel positive
LAG1	-5 to 5	Extern	LAG processor 1
LAG2	-5 to 5	Extern	LAG processor 2
ATT1	-5 to 5	Extern	Attenuator 1
ATT2	-5 to 5	Extern	Attenuator 2
ATT3	-5 to 5	Extern	Attenuator 3
VC1 to VC8	-5 to 5	MIDI	assignable MIDI CC

2 For the S/H input, this source is replaced by **RND**, a random signal (white noise).

Trigger Sources		
Name	Group	Description
off	-	off / default
KBD	Intern	Keyboard Trigger
Sng	Intern	Keyboard Single Trigger
Mlt	Intern	Keyboard Multiple Trigger
MG1A	Intern	MG1 (block A) clock
MG2A	Intern	MG2 (block A) clock
MG1B	Intern	MG1 (block B) clock
MG2B	Intern	MG2 (block B) clock
MG1C	Intern	MG1 (block C) clock
MG2C	Intern	MG2 (block C) clock
S/H	Intern	S/H clock
Clk1 to Clk4	Extern	external clock
Trg1	Extern	MIDI CC trigger
Trg2	Extern	MIDI CC trigger

Block Parameters

Each block has 61 parameters. The ID of a block parameter is given by the ID in the following tables plus an offset of 61 for block B and an offset of 122 for block C.

Temperament (Micro-Tuning)

parameter	ID	description
<i>Tune C to B</i>	0 – 11	individual tuning for keys C to B

Signal Generators

parameter	ID	description
<i>SG Waveform</i>	12	waveform (<i>Triangle, Sawtooth, Square, Rectangle, Pulse, Pulse Width Modulation</i>)
<i>SG PWM Intensity</i>	13	intensity of the Pulse Width Modulation
<i>SG Fine Tune</i>	14	frequency fine tuning
<i>SG Coarse Tune</i>	15	frequency coarse tuning
<i>SG Octave</i>	16	Octave (<i>16', 8', 4', 2'</i>)
<i>SG Frequency Mod Enable</i>	17	activates the Frequency Modulation
<i>SG Frequency Mod Reverse</i>	18	polarity of the Frequency Modulation
<i>SG Frequency Mod by MG1</i>	19	Frequency Modulation amount of MG1
<i>SG Frequency Mod by Ext</i>	20	Frequency Modulation amount of external/patched source
<i>SG Frequency Mod Source</i>	21	external/patched modulation source for Frequency Modulation
<i>SG Pulse Width Mod Source</i>	22	external/patched modulation source for Pulse Width Modulation

Lowpass Filter

parameter	ID	description
<i>LP Cutoff Frequency</i>	23	cutoff frequency
<i>LP Peak</i>	24	peak (resonance)
<i>LP Balance</i>	25	keyboard balance (tracking)
<i>LP Expand</i>	26	intensity of modulation by Envelope Modifier
<i>LP Frequency Mod Enable</i>	27	activates the Cutoff Frequency Modulation
<i>LP Frequency Mod by MG1</i>	28	Cutoff Frequency Modulation amount of MG1
<i>LP Frequency Mod by Ext</i>	29	Cutoff Frequency Modulation amount of external/patched source
<i>LP Frequency Mod Source</i>	30	external/patched modulation source for Cutoff Frequency Modulation

Envelope Modifier

parameter	ID	description
<i>EM Attack</i>	31	Attack time
<i>EM Decay</i>	32	Decay time
<i>EM Sustain</i>	33	Sustain level
<i>EM Release</i>	34	Release time (<i>Damp, Half Damp, Release</i>)
<i>EM Hold</i>	35	activates the Hold function
<i>EM Attack Time Mod Source</i>	36	external/patched modulation source for Attack time
<i>EM Release Trigger Source</i>	37	external/patched trigger source for Release phase

Resonators

parameter	ID	description
<i>Resonators Intensity</i>	38	mix between original and Resonators effect signal
<i>Resonator 1 Frequency</i>	39	peak frequency of first resonator
<i>Resonator 2 Frequency</i>	40	peak frequency of second resonator
<i>Resonator 3 Frequency</i>	41	peak frequency of third resonator
<i>Resonators Frequency Mod by MG2</i>	42	activates the Peak Frequency Modulation by MG2
<i>Resonator Peak Frequencies Mod Source</i>	43	external/patched modulation source for Peak Frequency Modulation

Signal Modifiers and VCA

parameter	ID	description
<i>Amplitude Mod Intensity</i>	44	intensity of the Amplitude Modulation
<i>Amplitude Mod by MG1</i>	45	activates the Amplitude Modulation
<i>Keyboard Balance</i>	53	volume balance of low versus high notes
<i>Volume</i>	54	volume of the block
<i>Panorama</i>	55	panorama position of the block
<i>VCA Amplitude Mod Source</i>	56	external/patched modulation source for VCA
<i>Channel Enable</i>	57	enables/disables the block signal
<i>Gate Mod Source</i>	58	external/patched modulation source for channel gate

Modulation Generators 1/2

parameter	ID	description
<i>MG1 Waveform</i>	46	Waveform (<i>Triangle, Falling Sawtooth, Rising Sawtooth, Square, Pink Noise, White Noise</i>)
<i>MG1 Frequency</i>	47	frequency
<i>MG1 Frequency Mod Source</i>	48	external/patched source for frequency modulation
<i>MG Signal Mod Source</i>	49	external/patched source for MG1 intensity modulation
<i>MG1 Sync to Host</i>	50	sync to host tempo rate
<i>MG2 Frequency</i>	51	frequency
<i>MG2 Sync to Host</i>	52	sync to host tempo rate

Tweaks

parameter	ID	description
<i>Override EM Release switch</i>	59	activates the EM Release time override
<i>EM Override Release Time</i>	60	override for EM Release time

Global Parameters

Global VCA and Controls

parameter	ID	description
<i>Total Volume</i>	183	the overall volume
<i>VCA Amplitude Mod Source</i>	184	external/patched modulation source for Total VCA
<i>KBD Trigger</i>	185	number of keys to be pressed for KBD triggering
<i>Pitch Bend Range</i>	186	range of the Pitch Bend modulation

Sample & Hold

parameter	ID	description
<i>S/H Clock Frequency</i>	187	sample clock rate
<i>S/H Synchro</i>	188	activates the Synchro function
<i>S/H Input Source</i>	189	sample input source
<i>S/H Sync to Host</i>	190	sync to host tempo rate

General Envelope Generator

parameter	ID	description
<i>GEG Delay</i>	191	Delay time
<i>GEG Attack</i>	192	Attack time
<i>GEG Release</i>	193	Release time
<i>GEG Auto</i>	194	activates the Auto function
<i>GEG Trigger Source 1</i>	195	external/patched trigger source 1
<i>GEG Trigger Source 2</i>	196	external/patched trigger source 2

Voltage Processors 1 and 2

parameter	ID	description
<i>VP1 Limiter A</i>	197	Limiter A of VP1
<i>VP1 Limiter B</i>	198	Limiter B of VP1
<i>VP1 Input Source</i>	199	input source of VP1
<i>VP2 Limiter A</i>	200	Limiter A of VP2
<i>VP2 Limiter B</i>	201	Limiter B of VP2
<i>VP2 Source Select</i>	202	sets the input source of VP2 (<i>VP1</i> or <i>VP2</i>)
<i>VP2 Input Source</i>	203	input source of VP2

External Modulation and Trigger Sources

parameter	ID	description
<i>Clock1 Source to Clock4 Source</i>	204 – 207	sync to host rate for Clk1 to Clk 4
<i>Trigger1 Source</i>	208	MIDI CC assignment for Trg1
<i>Trigger2 Source</i>	209	MIDI CC assignment for Trg2
<i>VC1 Source to VC8 Source</i>	210 – 217	MIDI CC assignment for VC1 to VC8

Tweaks

parameter	ID	description
<i>Use PS3300 Hold Function Mode</i>	218	activates the PS-3300 Hold function mode behaviour
<i>LAG1</i>	219	slew rate for LAG processor 1
<i>LAG1 Source</i>	220	input source for LAG processor 1
<i>LAG2</i>	221	slew rate for LAG processor 2
<i>LAG2 Source</i>	222	input source for LAG processor 2
<i>Attenuator1</i>	223	factor for Attenuator 1
<i>Attenuator1 Source</i>	224	Input source for Attenuator 1
<i>Attenuator2</i>	225	factor for Attenuator 2
<i>Attenuator2 Source</i>	226	Input source for Attenuator 2
<i>Attenuator3</i>	227	factor for Attenuator 3
<i>Attenuator3 Source</i>	228	Input source for Attenuator 3

Frequently Asked Questions

Before you read on here, please make sure that you also have read my statements regarding the FB-3300's capabilities and limitations at the beginning of this manual (see section *Digital Transformation*).

How do I install the FB-3300 (Windows 32 bit version)?

Just copy the files `fb3300.dll` and `fb3300.ini` from the ZIP archive you have downloaded to your system's or favorite DAW's VST plug-in folder. Your DAW should automatically register the FB-3300 VST plug-in the next time you start it.

How do I install the FB-3300 (Windows 64 bit version)?

Just copy the file `fb330064.dll` and `fb3300.ini` from the ZIP archive you have downloaded to your system's or favorite DAW's VST plug-in folder. Your DAW should automatically register the FB-3300 VST plug-in the next time you start it.

Note: You may have to remove any existing (32 bit) `fb3300.dll` from your VST plug-in folder or else your DAW may screw the versions up...

How do I install the FB-3300 (Mac VST/AU universal 32/64 bit)?

Locate the downloaded PKG package file `fb3300_1_0_5_mac.pkg` in Finder (!) and do a right- or control-click on it. In the context menu, click on "Open". You will be asked if you really want to install the package because it comes from an "unidentified developer" (me 😊). Click "OK" and follow the installation instructions.

What is the plug-in ID of the FB-3300?

The ID is `fb33`.

Will you support the FB-3300?

Yes. If you have problems, found a bug, or have some suggestions about the FB-3300 please send me a mail: full.bucket@gmx.net .

Does the PS-3300 have a status LED for the GEG?

Nope, I added that to the FB-3300 for convenience.

How do I know if a new version of the FB-3300 is available?

When connected to the Internet, open the Options menu (see section *Options Menu*) by clicking the disk icon and select the entry "Check Online for Updates". If a new version of the FB-3300 is available on fullbucket.de the respective information will be shown in a message box.